



Renewable Energy Deployment in the Maldives



Ismail Shafeeq
Ministry of Finance and Treasury

April 2008

Introduction





Introduction

- The Maldives is an archipelago of 1,190 low lying coral islands in the Indian Ocean. The country has a population of 300,000 people distributed over 194 islands. Over half of the inhabited islands have a population of less than 1,000 people. Only 2 percent of islands have a population of over 5,000 people. The wide uneven distribution of the population poses many development challenges including the high unit cost of providing social and economic services and infrastructure. In addition, the difficulties of access and the inherent fragility of the environment combine to create one of the most vulnerable communities in the world.



Introduction

- The Maldives is most vulnerable and almost undefendable to the projected impact of climate change.
- In the 26 December 2004 Asian Tsunami, the power infrastructure of the Maldivian islands were badly affected.
- Damages include: failure of power systems of the islands by damaging existing diesel generators, damaging existing electricity distributions networks and street lights and also destroying islands imported fossil fuel resources. Loss of communication within the country.
- It is urgently required to strengthen existing power systems in the islands by incorporating more reliable and sustainable means of electricity generation, such as wind turbines and photovoltaic panels into the existing power system.



Introduction

- The **7th National Development Plan 2006-2010** and the recently formulated **National Energy Policy** and **National Energy Plan** has put a strong emphasis to enhance national energy security by promoting indigenously available renewable sources of energy.
- Government has given a top priority to identify all relevant mechanisms and modalities to achieve maximum penetration of RE in the electricity generation mix.
- For RE Government has set a target of minimum of 12% contribution in the overall energy mix by the year 2015 through identification and development of innovative approaches such as 100% RE Islands.



Current Situation

- Islands have their independent power houses and electricity distribution networks.
- In general, the power supply systems in most of the outer islands have been developed on an adhoc basis and unprofessionally by the island communities. The results are an unreliable supply, low efficiency, poor quality, and high costs.
- Presently, in all the islands of the Maldives the electricity demand is met by diesel generators.
- These generators depend on imported and centrally stored fossil fuel resource. This situation is very vulnerable and may lead to power cut for a long period of time in case of natural disaster, bad weather & bottle neck in over seas oil supply.



Current Situation

- Total installed power on the 197 inhabited islands: 110 MW
- 197 islands with 24hrs electricity
- 87 energy intensive resort islands
- The electrification needs of the country are presently met by STELCO (35%), the IDCs or private (Diesel) power generators (13%).
- 48% installed on resort islands
- 4% installed in airports



Our Priorities

- **Provide alternative power systems for Islands for energy security & survival**
- **Expand the use of RE in tourism resorts to reduce the country's dependence on imported fossil fuels and address the sustainability of a key economical sector of the country.**
- **Contribute additional funds to the revolving fund of the UNDP-GEF Renewable Energy Technology Development and Application Project (RETDAP) project which provides concessional financing for investments in this sector.**
- **Capacity building in RE technologies**



Objective

- Increase reliability and sustainability of power system of the communities
- Providing electricity to the key public buildings of the community, in case of power failure
- Reduce dependence of imported fossil fuel and minimize impact of fossil fuel price fluctuation to the economy
- Reduce emissions of green house gas from burning of fossil fuel
- Increase energy security
- Build capacity in the sector



Provide alternative power systems for Islands for Energy Security and Survival

- Need an effective financing mechanism
- Need a financially competitive environment for RE power projects in order to compete with conventional fuel power projects
- Need provision of subsidy for RE
- Need import duty concession for RE components
- Need revolving funds for RE



Examples: Typical project

- **Grid connected Wind – Solar – Diesel Hybrid system with a battery bank.**
- **Grid Connected Solar-Diesel Hybrid system with a battery bank.**
- **Grid Connected Wind-Diesel Hybrid system with a battery bank.**
- **Stand alone wind or solar power supply systems.**

Example



Source: Japan International Cooperation Agency (JICA), The study on Tsunami Recovery, Rehabilitation and Development of Islands in Maldives.

Example

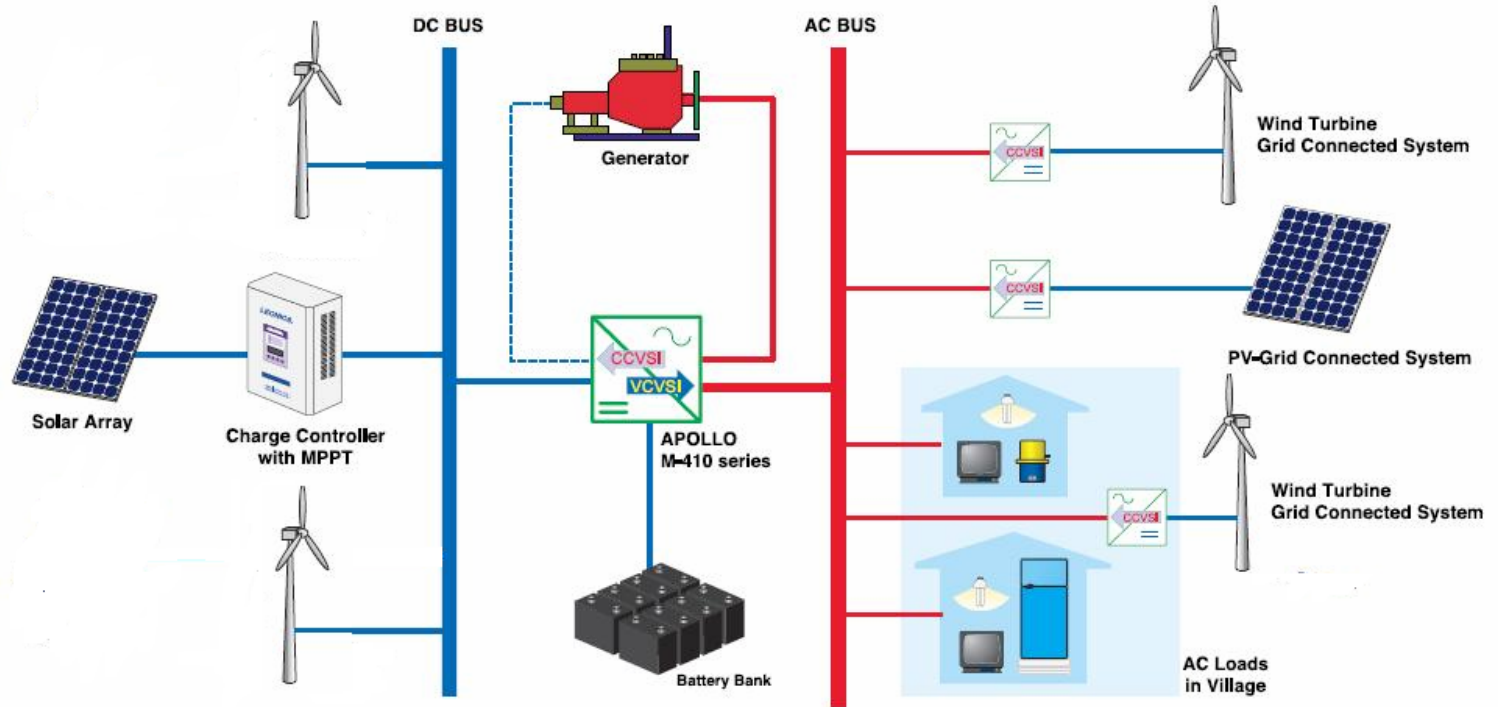



A system overview

- A solar/wind diesel fuel hybrid system gives the opportunity for users to get familiar with new photovoltaic system, without getting rid of the old trusted technology at once.
- the PV array, or the wind turbine and the generator supplement each other. the RET reduces the fuel use and maintenance costs of the generator and the generator replaces the part of the PV system that would need to be oversized to ensure an uninterrupted supply of power

On going projects

- Multipurpose Building in Laamu Atoll Gan under Japanese Grant Aid.



Source: Japan International Cooperation Agency (JICA), The study on Tsunami Recovery, Rehabilitation and Development of Islands in Maldives.

On going projects

- Atoll office building in Laamu Atoll Fonadhoo under Japanese Grant Aid.



Source: Japan International Cooperation Agency (JICA), The study on Tsunami Recovery, Rehabilitation and Development of Islands in Maldives.

On going projects

- Solar diesel hybrid system in Alif Dhaalu Atoll Mandhoo Island.



On going projects

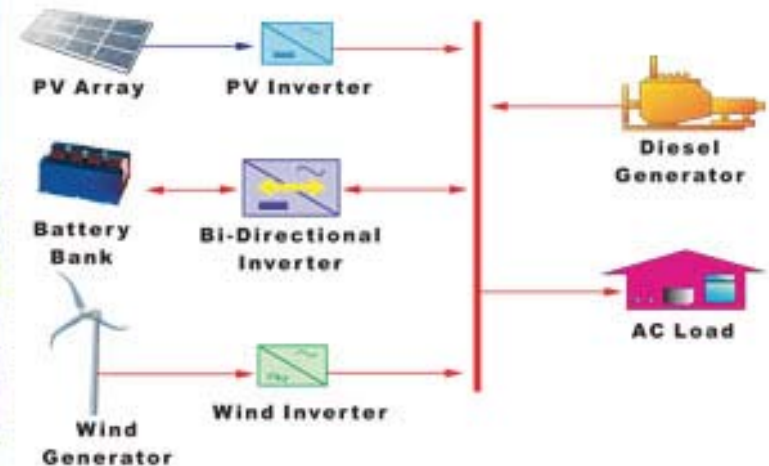

- Solar-Wind-Diesel Hybrid system in Ha. Uligan



Justification and Benefits

- Introduction of alternative means of electricity generation by using wind turbines and photovoltaic panels will be designed to prevent total power failure from the community in critical situations.
- The system/component installed under this project will supply electricity to the key public buildings of the community including island office, mosque, school, health centre, etc.
- Public can have access to limited power in critical situations.



Revolving Fund

- Neither the Government nor the private sector have funds to set up capital-intensive physical infrastructure for renewable energy projects. Furthermore, the high hardware costs involved in constructing renewable energy projects cannot be borne by communities or entrepreneurs without governmental or international partner support.
- The Renewable Energy Technology Development and Application Project (RETDAP) is a Global Environment Facility (GEF) co-financed project, implemented by the United Nations Development Programme (UNDP) and executed by the Ministry of Environment, Energy and Water (MEEW) in the Maldives.
- One of the challenges hindering the development and implementation of RE technologies in the country is the insufficient financial and economic incentives to undertake RE ventures.



Revolving Fund

- In order to encourage the government and private sector to provide financial assistance to the development and implementation of RE-based energy projects, as well as livelihood and productive use initiatives that will utilize energy from RE-based projects, the Renewable Energy Technology Development and Application Project (RETDAP), foresees the introduction of a consistent and sustainable Financial Mechanism to financially support such initiatives in the country.
- The GEF is contributing with 250,000 US Dollars to start giving soft loans for the acquisition and implementation of RE technologies. Due to the high prices of RE applications, the financial mechanism component of the RETDAP project was design to mobilise/receive additional funds from a broad spectrum of donors.



RE in Resorts

- As the tourism sector has the greatest energy needs in the country the sector needs to be targeted in order to meet the Maldives RE target of 12% Renewable Energy by 2015.
- Among potential users of RE in the country, resorts are the most relevant for a broader use of RE because of their financial capability (and also concern) that makes them more attractive for RE manufacturers/entrepreneurs.



Capacity Building

- Technical skills are mostly limited to routine maintenance and operation of conventional diesel power generators. Most programmes and projects in the country must rely on technical assistance from international bodies and experts due to the lack of technical skills found locally.
- The capacity building component of the RETDAP project is the only initiative currently operational in this field. Due to limited funds, this initiative is only able to cover a certain amount of specialization courses.
- Need links educational institutions that can provide scholarship to relevant trainees.

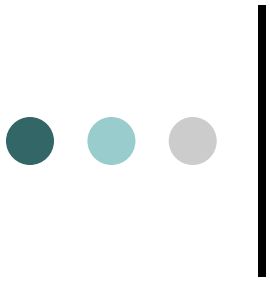

THANK YOU